

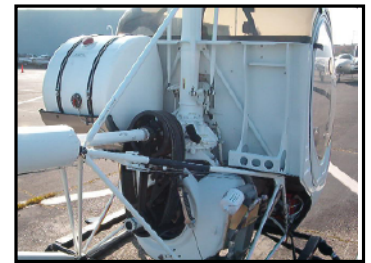

Spec Sheet - N2064Q

Price:	\$159,500
Serial number:	0094
Registration number:	N2064Q
Year:	1999
ACFT TT:	4397.5
Next overhaul engine:	
Seats:	2
Model:	300CB
Description:	Schweizer 269C-1
Flight Rule:	V. F. R.

* Note that all times are subject to change due to continuous daily operation at our facilities. Times are updated on a regular basis.



AIRCRAFT DESCRIPTION:

N2064Q is in excellent condition. Always maintained to highest commercial standards by our own certified Schweizer Service Centre.

The Schweizer 300CB Piston Helicopter is developed specially for personal transportation and the commercial training needs. It has very low life cycle cost and is therefore one of the most profitable training helicopters.

Powerplant:

Textron Lycoming HO 360 C1A Engine
 Maximum Take Off 180 shp... 134 kw
 Maximum continuous..... 180 shp... 134 kw

Fuel capacity..... 35 gal..... 95 kg

Performance

VNE [Kias] at sea level..... 94 kts..... 174 km/hr
 Cruise Speed..... 80 kts..... 148 km/hr
 Maximum Endurance..... 3.3 hrs (35 gal)
 Maximum Range..... 240 mi..... 386 km
 Hover Ceiling IGE @ 1600lbs. 7,000 ft... 2133 m
 Useful Load..... 662 lbs.... 300 kg

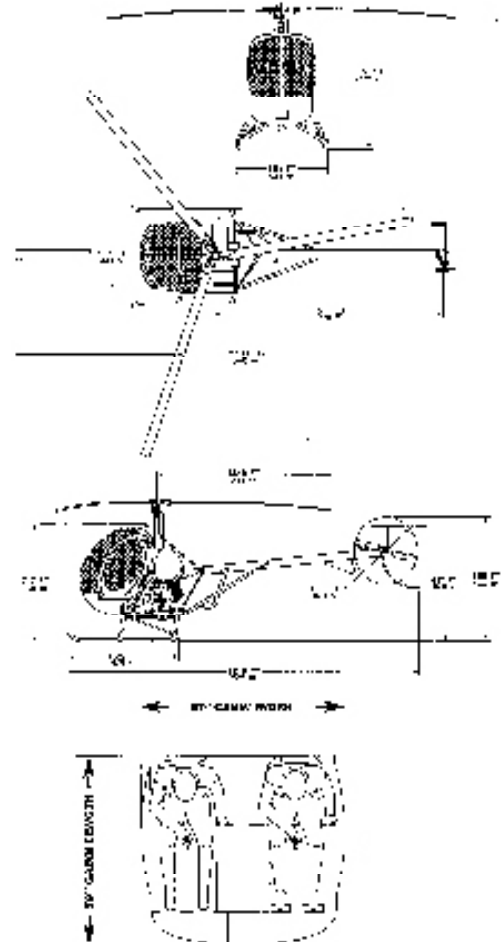

Spec Sheet - N2064Q

- CONTINUED

AIRCRAFT DESCRIPTION:

Avionics/ Radios:

- Bendix/King KX155 Nav/Com
- KT76A Transponder
- ACK A-30 Blind Encoder
- Switchable Hot Mic Intercom System
- Circuit Breaker protection
- Night Lights w/Strobe Beacons
- Modular Electrical Harness
- Cabin Accessory Plug
- 70 Amp Alternator.

Additional Equipment:

- Vertical Speed Indicator
- VOR
- Vertical Card Compass
- Weight on skids hour Meter
- Extra heavy duty Skid Shoes.

Exterior description:

- Year Painted: 1999
- Everything in excellent condition, all white.

Interior description:

- Year Interior: 1999
- Adjustable ventilation system
- Tinted Canopy Windows
- Glove box
- Pilot map light
- Two seat grey cushioned interior
- Grey Rubber Floor Mat with metal skid plates.
- Lap Belts and shoulder Harnesses.

Inspection status:

Current to all AD's and Service Bulletins, Aircraft is maintained to Commercial standards.

- Next Annual March 2012
- Next transponder cert. is due October 2011

COMPONENT HOURS REMAINING*:

COMPONENT	SERVICE LIFE	TIME REMAINING
Main Rotor Blade	5500	2576.0
Main Rotor Blade	5500	400.0
Main Rotor Blade	5500	400.0
M/R Pitch Shaft	4000	1829.0
M/R Pitch Shaft	4000	1829.0
M/R Pitch Shaft	4000	1829.0
M/R Damper	6000	4959.0
M/R Damper	6000	4959.0
M/R Damper	6000	1602.0
M/R Mast	13590	9192.0
Tailboom Strut	10700	6302.0
Tailboom Strut	10700	6302.0
Tailboom	4200	3968.0
Horizontal Stab	4200	3846.0
M/R Thrust Brng	4200	4002.0
M/R Transmission	4000	3601.0
M/R Trans Pinion	8000	7601.0
M/R trans Carrier	8000	3607.0
M/R Hub (SPLINED)	8000	7601.0
M/R Driveshaft (SPLINED)	4000	3601.0
Lower Coupling Shaft	6000	1600.0
T/R Transmission	4200	888.0
T/R Input shaft	8600	5288.0
T/R Blade	9000	6338.0
T/R Blade	9000	6338.0
T/R Drive Shaft	6000	5133.0
T/R Retention Strap	5100	702.0
Engine Assembly	2200	1846.0

* Note that all times are subject to change due to continuous daily operation at our facilities. Times are updated on a regular basis.

CONTACT INFORMATION
 Helicopter Sales: Paul Mouisset
 Phone: (337) 335 2919
 Toll Free: (800) 365 6771
 e-mail: paul.mouisset@bristowgroup.com
 web: www.heli.com
 Address: 4605 Industrial Drive, New Iberia, LA 70560.