

THE ULTIMATE IN VERSATILITY!

**The Schweizer 300C
Piston Helicopter**

300C



The Schweizer Model 300C helicopter is known the world over as the finest and most versatile piston engine helicopter. Through a program of continuous design evolution and innovation, the new Model 300C is now even better than ever.

The “new” Model 300C provides:

1. Superior performance for a broad range of roles.
2. Unequalled maneuverability.
3. Inherent flight stability and responsive handling characteristics.
4. Excellent visibility and spacious cockpit.
5. Low noise characteristics for quiet operation.
6. Outstanding range and endurance.
7. Designed in crashworthiness features second to none.
8. Proven safety record.
9. Field replaceable components for easy maintenance.
10. Lower insurance rates for all owners and operators through the Schweizer Insurance program.

In addition, the Model 300C is supported by a Worldwide Service Center network. The Schweizer Model 300C-mission capable, effective, affordable - Everything a helicopter should be. For more information and the name of the distributor near you, contact Schweizer Aircraft today.

THE MORE YOU KNOW THE BETTER YOU'LL LIKE THE SCHWEIZER!

Schweizer Model 300C

PERFORMANCE

Vne (Kias) at sea level	95 Kts.	176 km/hr
Cruise Speed	86Kts.	159 km/hr
Maximum Endurance	3.8 hrs	3.8 hrs
Hover Ceiling IGE @ 1700 lbs.	10,800 ft	3292 m
Hover Ceiling OGE @ 1700 lbs.	8600 ft	2621 m

DIMENSIONS

Height (overall)	8.72 ft.	2.65 m
Length (overall)	30.83 ft.	9.40 m
Fuselage length	22.19 ft.	6.76 m
Landing gear tread width	6.54 ft.	1.99 m

WEIGHT

Empty weight	1,100 lbs	499 kg
Gross weight	2,050 lbs	930 kg
Useful load	950 lbs	431 kg

POWERPLANT

Textron Lycoming HIO-360-D1A Engine		
Maximum Take off	190 shp	141 kw
Maximum Continuous	190 shp	141 kw

ROTOR SYSTEM

Main rotor diameter	26.83 ft	8.18 m
Main rotor disk areas	565 sq ft	52.49 sq m
Main rotor RPM	471	
Tail rotor RPM	4.25 ft	1.30 m

FUEL

Standard capacity	32 gal	192 lbs	87 kg
Auxiliary Fuel	64 gal	384 lbs	174 kg

SEATING CAPACITY

Training	2 seats
Utility	3 seats

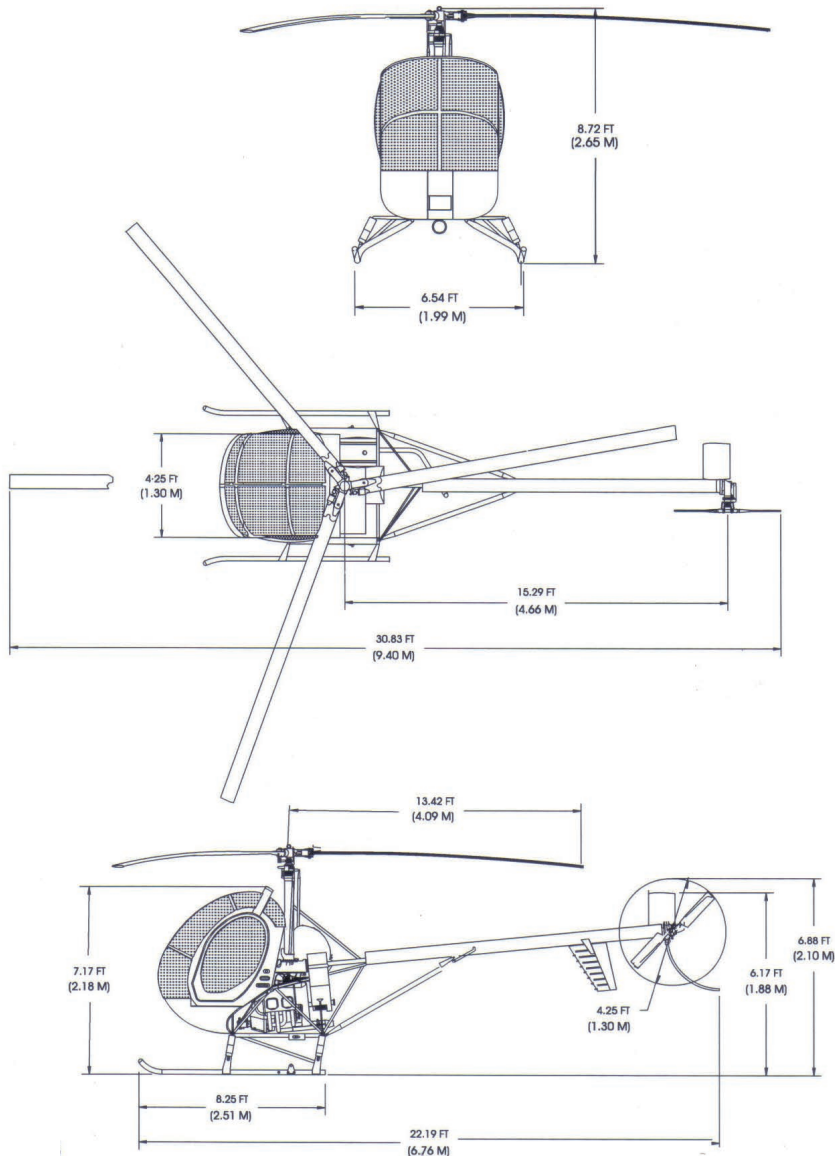

THE ULTIMATE IN VERSATILITY

The model 300C has proven its value in many diverse applications around the world including:

- Personal transportation
- Military and civilian training
- Aerial Photography • Law enforcement patrol
- Powerline/traffic patrol • Aerial application
- Fish and game spotting • Lift operations

SPACIOUS TWO- OR THREE-PLACE COCKPIT

